

# PRODUCT DESCRIPTION



With 4 and 7 ton nominal towing capacity the dependable Clark CTX40/70 electric tow tractor is the ideal choice for many applications. Whenever an efficient transport of multiple trailer loads is required, the rugged construction ensures durability and consistent reliability throughout the application. The operator's compartment provides a safe and comfortable working environment.

## Operator's Compartment

Access to the ergonomically designed operators compartment is easy via a low positioned entry. A full width rubber floor covering in the footwell area is totally uncluttered and prevents slippage. The impressive leg room, the adjustable steering column with two spoke steering wheel together with an easy-to-adjust, yet comfortable CLARK-seat, allow perfect adaptation to any driver.

All control elements are placed in easy-grip position. Large accessible storage compartments as well as quick access to an ideally positioned automotive style hand brake and emergency stop button complete this impressive operator's compartment.

A generous 200kgs capacity storage area (767mm width x 420mm length) located behind the driver's seat allows easy storage of ancillary items.

The battery charge indicator is located within easy view of the operator giving instant battery condition information at all times.

The optional inching function allows smooth approach to the trailer for easy hook up. Slow creep speed is available via the optional creep speed function allowing full customization of the tractor to every application.

## Motor, drive and control

A powerful 3.0 kW AC motor (CTX40) or 6,0kW (CTX70) driving the rear wheels and 48 Volt three-phase current technology ensure excellent acceleration, smooth control and high performance. The maintenance free AC motors ensure running costs are kept to a minimum.

The temperatures of the motors and controller are constantly monitored with the power being automatically adjusted to prevent design limits being exceeded. The ZAPI AC controls are easily accessible and equipped with modern MOSFET and CAN-bus technology. Competitive travel speeds, even under load are a major feature of the CTX range of towtractors from CLARK.

## Brake system

Three independent brake systems (electrical, foot and parking brake) ensure increase efficiency through improved utilization of the battery capacity and high levels of safety. The foot and parking brake provides constant brake performance in all conditions. The regenerative electrical brakes returns energy to the battery during each braking action. This process saves energy costs, reduces brake wear and extends the driving time per battery charge.

If the driving direction is changed by operation of the direction lever, the electronics ensures gentle braking and progressive acceleration in the new direction of travel. The drum brakes are protected against aggressive particles. The standard ramp start feature enables controlled operation of the truck on gradients and precise handling on loading platforms.

The parking brake is connected via a Bowden cable directly to the drum brake.

## Steering system

An extremely small turning radius of 1700mm is possible due to the large steering angle. Full soft yet precise control is still possible even with the steering on full lock.

## Durable frame for long life

The CTX series from CLARK is designed to „Build to Last“ and is characterized by an especially strong frame construction, making it suitable for the toughest applications. The center of gravity of the chassis is extremely low giving excellent stability when cornering.

## Additional standard equipment

Front working lights, combination rear lights incorporating brake and reversing lights. Paintwork in the bright safety colour „CLARK Green“, rims in white, hydraulic drum brake, storage cargo box with 200kg of carrying capacity, tiltable steering wheel with spinner knob

## Options

Solid-tires, cabins, inching switch, creep switch, back up alarm, Reverse mirror

## Certification

The CTX40/70 series is CE certified and corresponds to all European safety standards.

Talk to your CLARK dealer to find the optimum equipment for you.

# CTX40/70

48 V Electric Tow Tractor  
Pneumatic Tires  
4.000 kg 7.000 kg

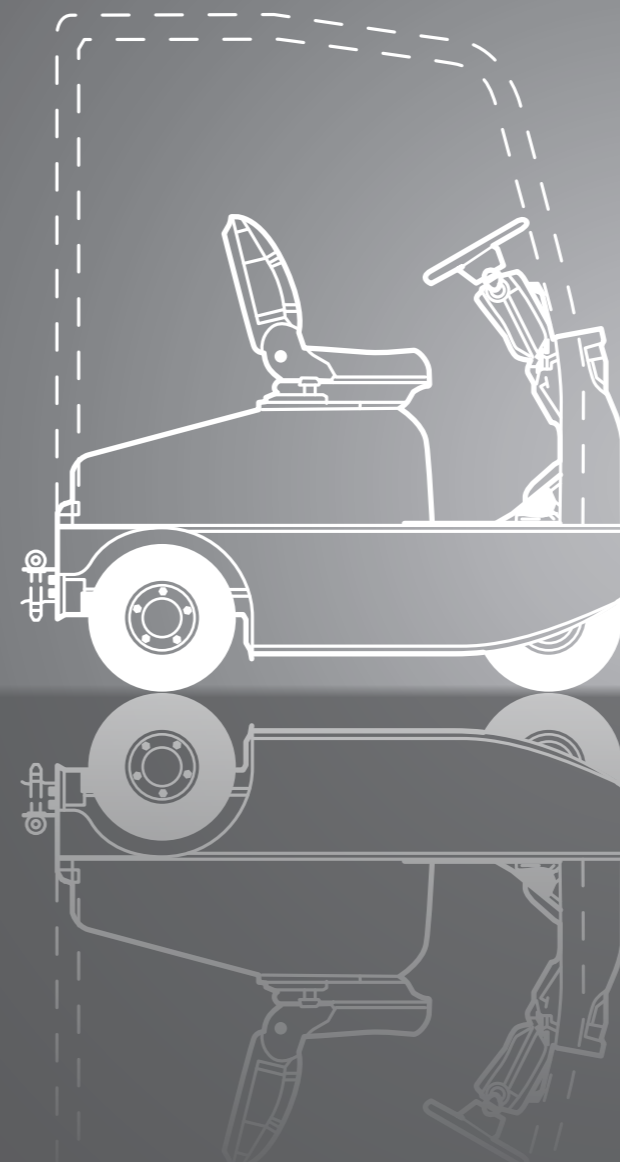

## CLARK Europe GmbH

Neckarstraße 37  
D - 45478 Mülheim an der Ruhr  
Tel.+49 208 377336 0  
Fax+49 208 377336 36  
email: info-europe@clarkmheu.com  
www.clarkmheu.com

En. 01/2011

# DIMENSIONS

## CTX40/70

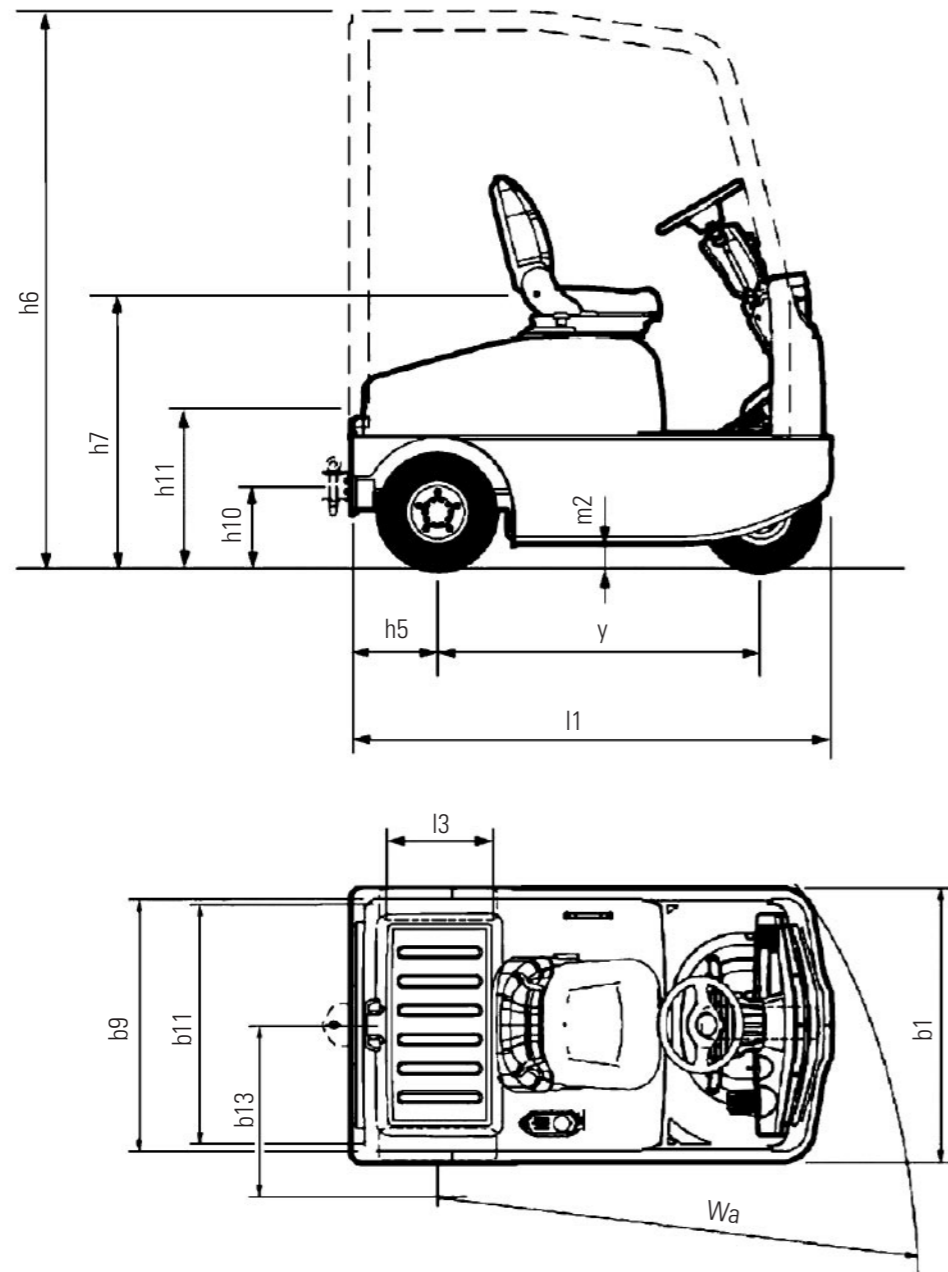

# SPECIFICATIONS

## Product Specifications acc. to VDI 2198

	1.1 Manufacturer (abbreviation)	CLARK	CLARK	
Specifications	1.2 Manufacture's type designation	CTX40	CTX70	
	1.3 Drive: electric, diesel, petrol, fuel gas	Elec-48V	Elec-48V	
	1.4 Operator type: hand, pedestrian, seated, standing	seated	seated	
	1.5 Load capacity / rated load	Q (t)	4	7
	1.7 Rated drawbar pull	N	785	1393
	1.9 Wheelbase	y (mm)	1160	1160
Weight	2.1 Service weight	kg	910	1050
	2.3 Axle loading, unladen front / rear	kg	390/520	430/620
Tires, Chassis	3.1 Tire type, P=pneumatic, SE=superelastic, C=cushion *1		P	P
	3.2 Tire size, front		4.00-8/6PR	4.00-8/6PR
	3.3 Tire size, rear		4.00-8/6PR	4.00-8/6PR
	3.5 Wheels, number front/rear (x=drive wheels)		1/2x	1/2x
	3.7 Tread, rear	b11 (mm)	870	870
	4.7 Height overhead guard (cabin):	h6 (mm)	2035	2035
	4.8 Seat height	h7 (mm)	920	920
Dimensions	4.12 Coupling height	h10 (mm)	295	295
	4.13 Loading height, unladen	h11 (mm)	605	605
	4.16 Length of loading surface	l3 (mm)	420	420
	4.17 Overhang	l5 (mm)	310	310
	4.18 Width of loading surface	b9 (mm)	767	767
	4.19 Overall length(With Hinge/Without Hinge)	l1 (mm)	1830/1730	1830/1730
	4.21 Overall width	b1, b2 (mm)	995	995
	4.32 Ground clearance, center of wheelbase	m2 (mm)	90	90
	4.35 Turning radius	Wa (mm)	1700	1700
	4.36 Minimum pivoting point distance	b13 (mm)	551	551
Performance	5.1 Travel speed laden/unladen	km/h	9/13	7/17
	5.6 Max. drawbar pull laden/unladen *2	N	-/5394	-/5982
	5.8 Max. Gradeability laden/unladen *2	%	-/51,1	-/55,6
	5.10 Service brake		Drum brake	Drum brake
Drive line	6.1 Drive motor rating, S2 60min	kW	3,0	6,0
	6.3 Battery acc. To DIN 43531/35/36 A,B,C, no		DIN 43531 A	DIN 43531 A
	6.4 Battery voltage / nominal capacity K5	V/AH	48/270	48/375
	6.5 Battery weight	kg	400	540
	Miscellaneous	8.1 Drive motor control		Inverter / AC
8.4 Sound level, driver's ear *3		dB (A)	68,4	69,5
8.5 Towing coupling, class/type DIN			bolt	bolt

\*1 Optional with super-elastic tyres \*2 At friction coefficient  $\mu=0.6$  with 1.6 km/h \*3 acc. to DIN EN 12053

## Gradeability

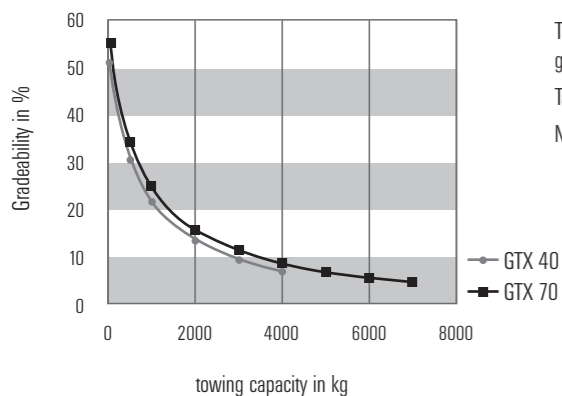

The gradeability diagram shows the combination of towing capacity and gradeability of the tow tractor.

Talk to your Clark dealer to find out more about your individual application.

Note: At friction coefficient  $\mu=0.6$  with 1.6 km/h